

RACK SYSTEM

ESCAB[®]

COPPER SYSTEM

- NETWORK UNIVERSAL SERIES
- ACTIVE SERIES 1000KG LOADING CAPACITY
- OPEN FRAME SERIES
- OUTDOOR DOOR STANDING CABINET

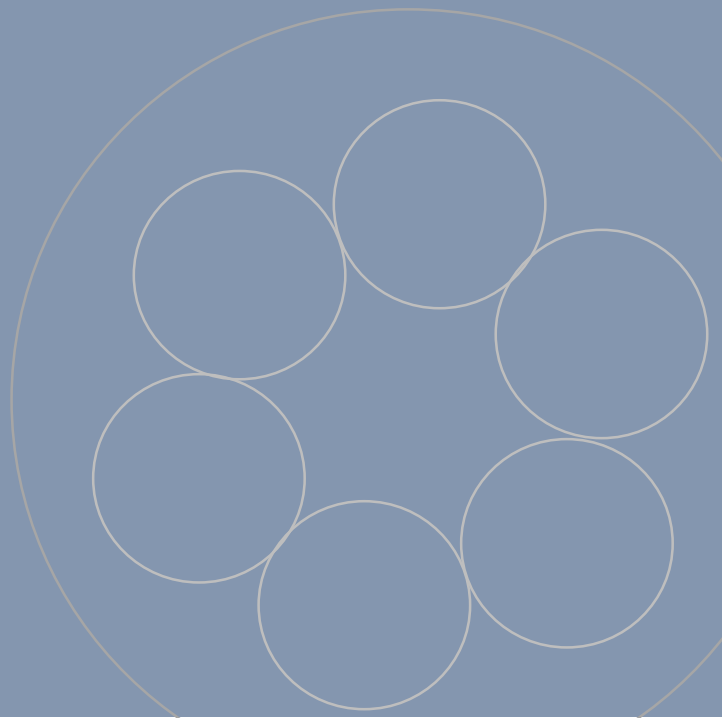

UNIVERSAL STANDARDS

NETWORK SERIES

W:600mm , W:800mm
D:600mm , D:800mm



The standard Network Series Escab rack cabinet has got, leveling feet, the front door is single wing metal frame glass door by single point espagnolette locking system, removable solid metal rear cover with "O" ring locking system and spring hinged, sliding type cable entry at the bottom cover and vented top cover by knocked out blanking plate for cable entry as a standard product. Please check accessories for other alternatives.

FEATURES

- Inner active ventilation by 4 units fan group. The fan group is an accessory.
- The 2 units fan is also an optional.
- Ventilation fan with and without thermostat,
- Perforated, solid metal and glass doors applications
- Single wing rear doors options
- Rack angles infinitely adjustable within the cabinet for easy adjustment to the desired position.
- There is knocked out blanked plates for cable entry at top cover.
- The Solid metal rear cover hinged spring and "O" locking system. Brushed Cable entry is an optional.
- Bottom sheet has 220mmX178 mm sliding type cable standard, brushed types for cable entries are optional.
- There is 6 pcs side carrier bars produced by 1,5mm galvanised steel parts at sizes between 32U - 47U for more higher loading capacity.
- Side metal panels are easily removable and include hinged spring latches & locks.
- Castor and/or levelling feet.
- Excellent strong chassis by adjustable profiles.
- Movable front and rear rack mounting angles, and "U" market for 19" mounting rails.
- User-friendly cable tray options.
- Wide range accessory variation for easy installation of 19" mounting

User friendly, smart engineering.
Removable, locking side panels for easy direction changes, and built-in fans to keep your equipment cool and safe.

RACK NETWORK SERIES

A - Front Door Types	B - Rear Door Types	Bottom Sheet Cable Entry
1-Single wing glass door with metal frame**	1-Flat sold metal single wing cover	1-The sliding type cable entry
2-Flat, %63 perforated single wing metal door	2-Flat, %63 perforated single wing metal door	2-The brushed cable entry
3-Flat, single wing solid metal door	3-Flat metal cover with brush type cable entry	3-The knocked out blanking plate cable entry

**It is standard product door type. Others are optionally offered upon request. The standard finishing colour is RAL 9005 Signal Black

STANDING TYPE NETWORK				
Size "U"	W*D (mm)			H (mm)
16U	600x600	600x800	800x800	830
20U	N16U6060-ABC	N16U6080-ABC	N16U8080-ABC	1010
26U	N26U6060-ABC	N26U6080-ABC	N26U8080-ABC	1280
32U	N32U6060-ABC	N32U6080-ABC	N32U8080-ABC	1550
36U	N36U6060-ABC	N36U6080-ABC	N36U8080-ABC	1720
42U	N42U6060-ABC	N42U6080-ABC	N42U8080-ABC	1990
45U	N45U6060-ABC	N45U6080-ABC	N45U8080-ABC	2005
47U	N47U6060-ABC	N47U6080-ABC	N47U8080-ABC	2120

Order Part Number: **N42U6080-133**

- N : Rack
- 42U Size 42U
- 6080 - 600x800
- 1 Front door model ; Single wing glass door with metal frame
- 3 Flat metal cover with brush type of entry
- 3 The knocked out blanking plate cable entry
- **The product's colour is RAL 9005 Signal Black as standard.**

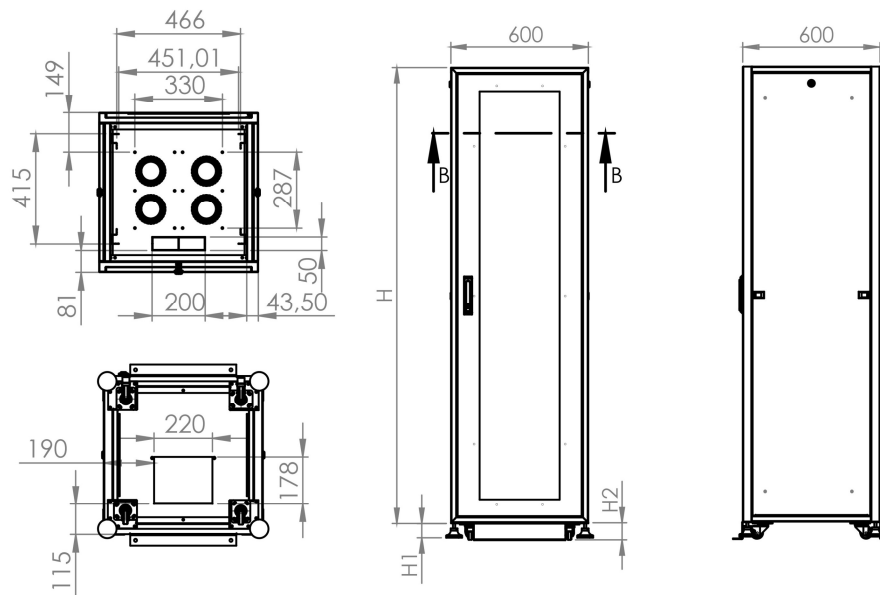

UNIVERSAL STANDARDS

NETWORK SERIES

W:600mm , W:800mm D:1000mm



The standard D:1000mm Network Series ESCOM Rack cabinet has got, leveling feet, the front door is single wing metal frame glass door by single point espagnolette locking system, removable solid metal rear cover with “O” ring locking system and spring hinged, the bottom cover has sliding type cable entry 220mmX178 mm and vented top cover by knocked out blanking plate for cable entry as a standard product. The standard cabinet has 2 pcs side covers with hinges springs and “O” type lock systems which provides you to easy access during installation. There are also 6 pcs omega carriers at each cabinets at sizes between 32U-47U. Please check accessories for other alternatives.

FEATURES

- Inner active ventilation by 4 units fan group. The fan group is an accessory.
- The 2 and 6 units fan is also optional.
- Ventilation fan with and without a thermostat,
- Perforated, solid metal and glass doors applications.
- Rack angles adjustable within the cabinet for easy adjustme to desired position and “U” market for 19” mounting rails.
- Top cover has a knocked out blanking plate for cable entry.
- The bottom sheet has 220mmX178 mm sliding type and a knocked out blanking plate for cable entries
- There are 6 pcs side carrier parts produced by 1,5mm galvanized steel parts between 32U to 47U sizes for more higher loading capacity.
- 2 pairs side metal panels are easily removable and include slide spring latches & locks.
- Castor and/or levelling feet.
- Excellent strong chassis.
- User-friendly cable tray options.
- Wide range accessory variation for easy installation of 19” mounting

User friendly, smart engineering.
Removable, locking side panels for easy direction changes, and built-in fans to keep your equipment cool and safe.

escab

RACK NETWORK SERIES

A - Front Door Types	B - Rear Door Types	Bottom Sheet Cable Entry
1-Single wing glass door with metal frame**	1-Flat sold metal single wing cover	1-The sliding type cable entry
2-Flat, %63 perforated single wing metal door	2-Flat, %63 perforated single wing metal door	2-The brushed cable entry
3-Flat, single wing solid metal door	3-Flat metal cover with brush type cable entry	3-The knocked out blanking plate cable entry
4-63% Perforated single wing metal door	4 - Flat, 63% perforated double wing metal door for D:800 mm cabinets.	

**It is standard product door type. Others are optionally offered upon request. The standard finishing colour is RAL 9005 Signal Black

STANDING TYPE NETWORK			
Size "U"	W*D (mm)		H (mm)
16U	600x1000	800x1000	830
20U	N16U60100-ABC	N16U80100-ABC	1010
26U	N26U60100-ABC	N26U80100-ABC	1280
32U	N32U60100-ABC	N32U80100-ABC	1550
36U	N36U60100-ABC	N36U80100-ABC	1720
42U	N42U60100-ABC	N42U80100-ABC	1990
45U	N45U60100-ABC	N45U80100-ABC	2005
47U	N47U60100-ABC	N47U80100-ABC	2120

Order Part Number: **N42U80100-211**

- N : Rack
- 42U Size 42U
- 80100 - 800x1000
- 1 Front door model ; 2-Flat, %63 perforated single wing metal door
- 3 Rear door type : 1-Flat sold metal single wing cover
- 3 Bottom sheet cable entry : 1-The sliding type cable entry
- **The product's colour is RAL 9005 Signal Black as standard.**

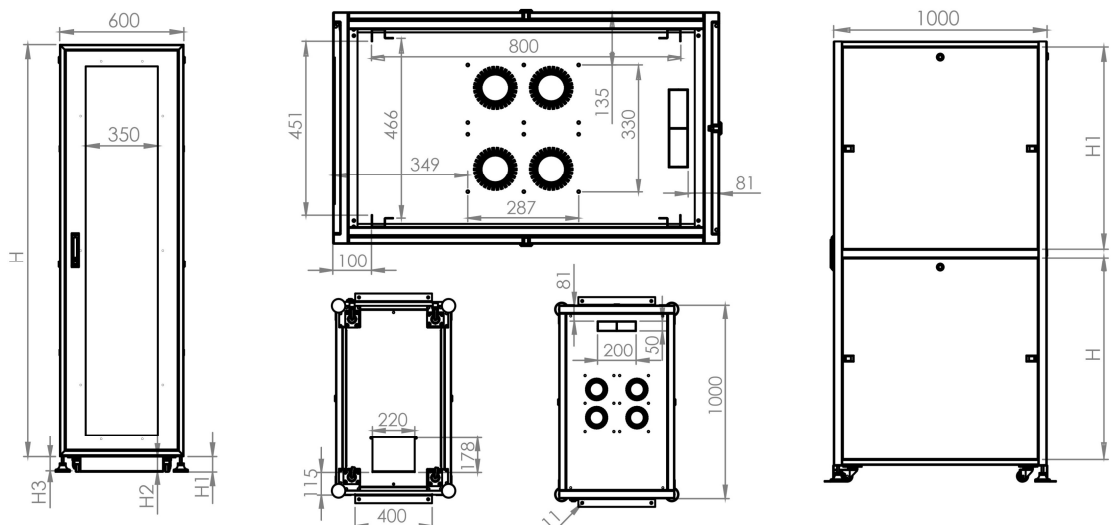

OPEN FRAME SERIES

NETWORK SERIES

The Escab Open Frame rack cabinets are one of the best-designed rack systems where no doors or panels are required such multicore cabling systems, well-isolated from external environmental conditions, dust and cost-effective for construction and transportation

The cabinets are totally knocked down design and best possible minimum packaging dimensions bring low-cost transportation and stock spaces. It is professional products where strong construction, higher passive & natural ventilation and inter-connection of other cabinets.

The Racksis open frame cabinets are offered single and double frame in different dimension between 26U to 47U. There are 2 pcs "L" shade 3 mm metal plates to fix on the ground. The installation is easy and quick. It is available to use leveling feet and castor set as optional.

The Ral 9005 Black and Ral 7035 Grey colors are available.

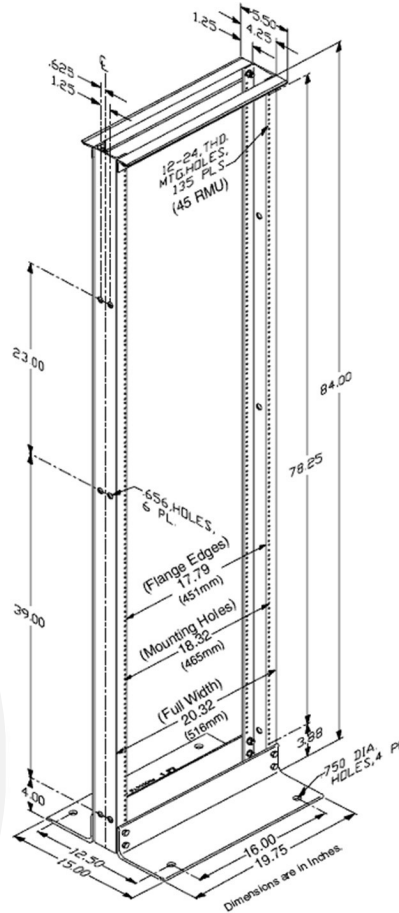

STANDING TYPE NETWORK			
Size "U"	W*D (mm)		H (mm)
	540x290	540x370	
26U	RO26U5429T	RO26U5437T	1324
36U	RO36U5429T	RO36U5437T	1769
42U	RO42U5429T	RO42U5437T	2036
45U	RO45U5429T	RO45U5437T	2170
47U	RO47U5429T	RO47U5437T	2258

User friendly, smart engineering. Removable, locking side panels for easy direction changes, and built-in fans to keep your equipment cool and safe.